

Product : Sewage treatment plant

Type : X-Perco® C-90
 Model : C-90 10 PE (2)
 Process : Tricking filter

PERFORMANCE

Considered influent water

Characterization :	Sewage*
Pollutant load BOD ₅ :	0.60 kg O ₂ /day
Pollutant load SS :	0.90 kg/day
Hydraulic load :	1.50 m ³ /day
NTK :	80 mg/liter
P :	17 mg/liter
Fat & Oil :	20 mg/liter

Purification performance

BOD ₅ :	< 25 mg O ₂ /liter
COD :	< 125 mg O ₂ /liter
SS :	< 30 mg/liter
NH ₄ :	< 2 mg/liter



* We recommend placing a grease trap for treating waste water generated by a restaurant, kitchens used for commercial purposes, etc.

OPERATION

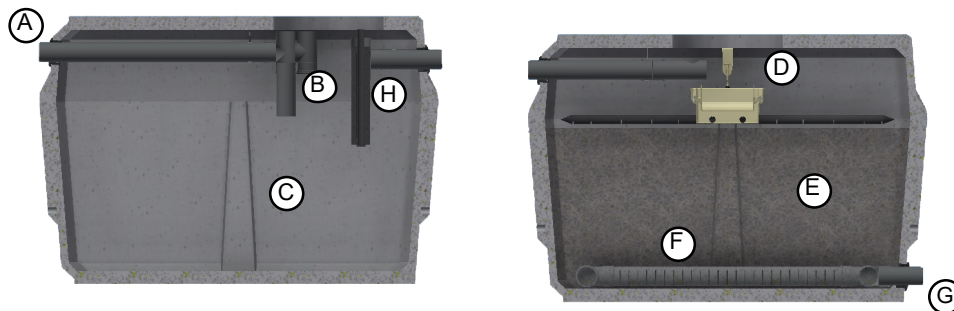

ELECTROMECHANICAL KIT

Components

Tank(s) :	High performance fiber reinforced concrete
Partition :	High performance fiber reinforced concrete
Effluent filter :	PE
Tipping bucket :	PVC/PE/PP/Stainless Steel
Tricking filter :	Xylit

Legend

A	High inlet
B	Ventilated T pipe
C	Primary settling compartment
D	Flow Distribution system
E	Tricking filter
F	Treated water discharge piping system
G	Low outlet
H	Effluent filter

SPECIFICATIONS

Tank :	10 years
Xylit :	10 years
Other equipment :	2 years
Resistance :	B125
Authorized backfill :	80 cm

OPTIONS

- 3 risers
- 3 lids

APPROVALS AND CERTIFICATES



: EN 12566-3 CPD 89/106/CEE

DIMENSIONS | VOLUMES | WEIGHT

Measure	Unit	Tank	Filter
Total height :	(cm)	150	150
Entry height :	(cm)	125	125
Exit height :	(cm)	121	9
Length :	(cm)	224	224
Width :	(cm)	162	162
Weight :	(T)	2.20	3.10
Footprint :	(m ²)	4.00	4.00
Manhole(s) :	(cm)	2 x Ø62	1 x Ø62
Ø In / Out :	(mm)	110/110	110/110

* tolerance ± 2 cm

SIZING

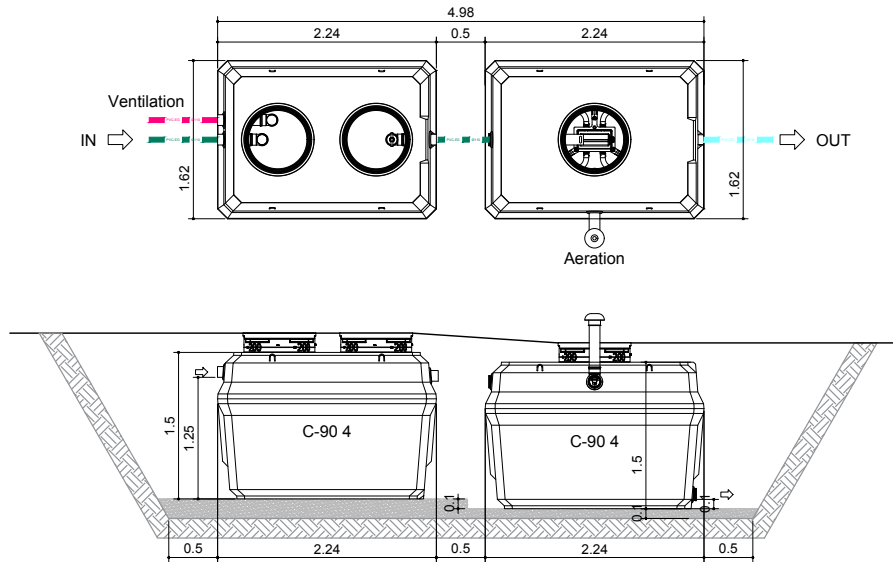

OPERATION

Useful volumes

Primary settling compartment :	3.03	m ³
Trickling filter compartment :	2.22	m ³

Operation

Theoretical draining frequency : every 13 months
 Advised maintenance frequency : yearly
 Effluent filter cleaning frequency : min. twice a year

Consumables

Xylit replacement :	10 years
Alarm battery :	7 years

Complementary accessories supplied with the product :

- 1 information pocket
- 2 effluent filters
- 1 level alarm
- 1 rotating bucket
- 1 key
- 2 90° Ø110mm FF elbow
- 2 Ø110mm ventilation cap
- 6 Ø110mm FF connection