

Product: Oil separator

Type : Hydrosep® HYDWWC90
 Model : C-90 6m³ - 15 l/s

PERFORMANCES

Fluids to treat :	Storm waters
Nominal size (NS) :	15 l/s
Low-density liquid :	≤ 0.95 g/cm ³
Sludge holding capacity :	1500 l
Hydrocarbon holding capacity :	1830 l
Post-treatment residual oil content :	< 5 mg/l (Class I)

DIMENSIONS | VOLUMES | WEIGHTS

Dimensions	Unit	
Total height* :	(cm)	225
Inlet height* :	(cm)	193
Outlet height* :	(cm)	182
Length :	(cm)	238
Width :	(cm)	158
Total volume :	(m ³)	6.00
Net capacity :	(m ³)	4.61
Weights :	(T)	3.45
Manhole(s) :	(cm)	2 x 60/60
Ø Inlet (IN) / Outlet (OUT) :	(mm)	200/200

* tolerance ± 2 cm

Materials

Tank :	High performance fibre-reinforced concrete (HPFR)
Pipe seals :	NBR (inlet and outlet)

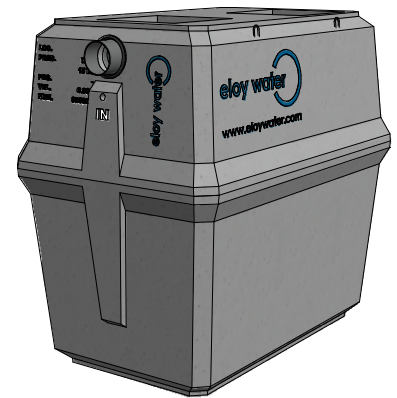

OVERALL SIZE

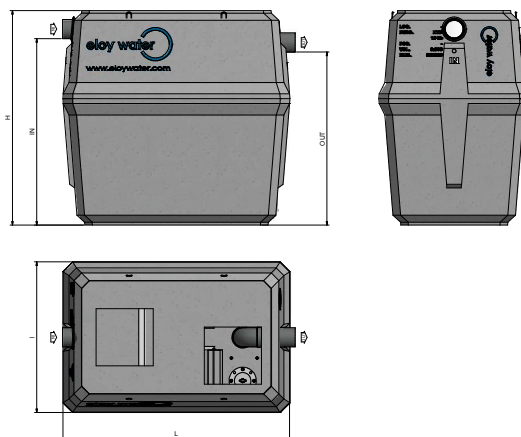

OPTIONS

- High oil level alarm
- High sludge and oil level alarm
- By-pass

WARRANTIES

Tank :	10 years
Accessories :	2 years
Strength :	B125

CERTIFICATES

CE : EN-858

Eloy Water reserves the right to modify, or more generally, to update this document at any time without prior notice.

Datasheet version: 20101012
 Product version: 20090217