

REMARKS:

1. **Installation requirements :**
Please read carefully the installation guide before any installation !!
2. **Dimensions tolerances:**
2%
3. **Option(s):**
Pipes, risers, lids and accessories in option.

X-PERCO C-90 10 PE (2)

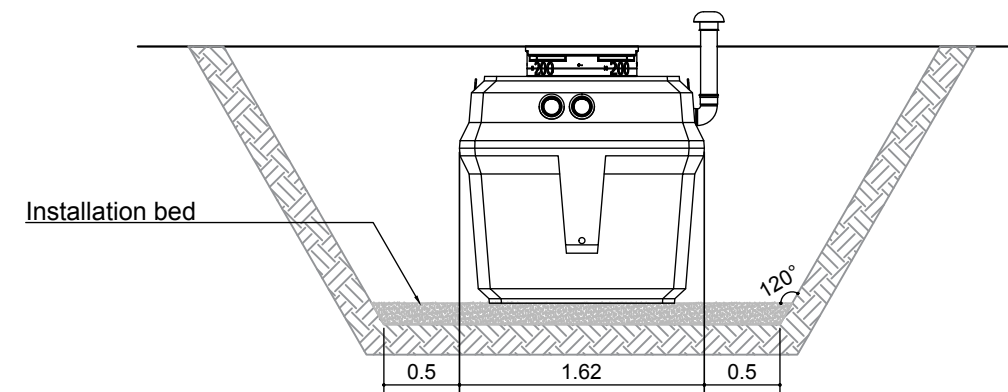
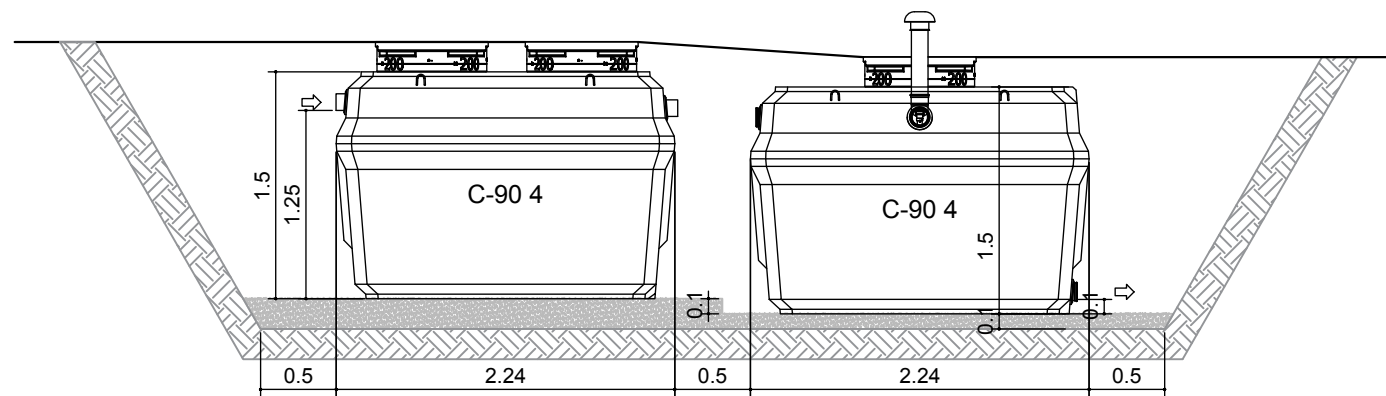
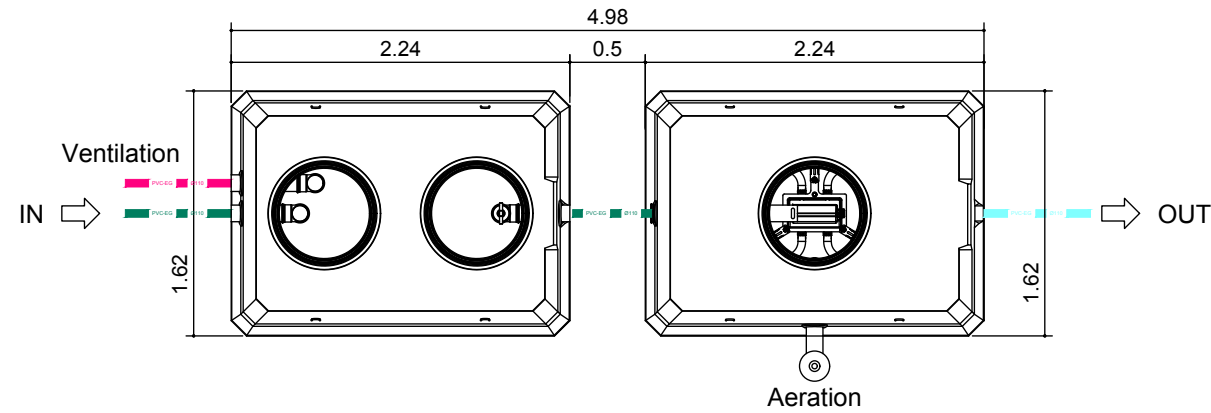

PIPING LEGEND	
Type of product conveyed (colour)	
■ Waste water	■ Air blower
■ Cleaned water	■ Ventilation
■ Sludge	■ Electric sheath

Rev	DESCRIPTIONS	DATE	DESIGNER	VERIFIED BY	VALIDATED BY
B		19/02/2020	ADMIN		
A		21/05/2019	ADMIN		

eloy water
 Zoning de Damré, rue des Spinettes 13
 4140 Sprimont (BELGIUM)
 Tel: +32(0)4/382.34.44
 http://www.eloywater.com - info@eloywater.com

X-PERCO C90 10 PE (2) / 1.5 m³/day	
Site plan	
STANDARD PRODUCT RANGE X-PERCO C90 WW	1/50 A3 EW-3900-10-I01-EN.dwg